

OXFORD IB STUDY GUIDES

Tim Kirk

# Physics

FOR THE IB DIPLOMA

2014 edition

OXFORD

## Translational and rotational motion

### CONCEPTS

The complex motion of a rigid body can be analysed as a **combination** of two types of motion: *translation* and *rotation*. Both these types of motion are studied separately in this study guide (pages 9 and 65).

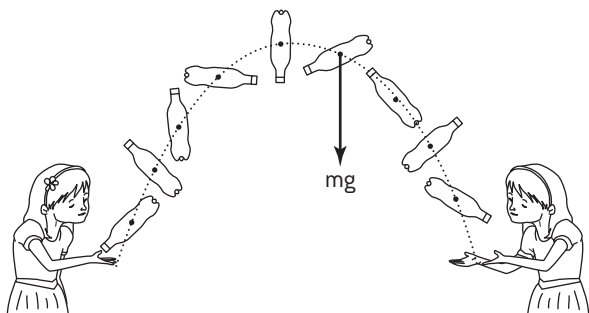

A bottle thrown through the air – the centre of mass of the bottle follows a path as predicted by projectile motion. In addition the bottle rotates about one (or more) axes.

Translational motion is described using displacements, velocities and linear accelerations; all these quantities apply to the **centre of mass** of the object. Rotational motion is described using angles (angular displacement), angular velocities and angular accelerations; all these quantities apply to circular motion about a given axis of rotation.

The concept of angular velocity,  $\omega$ , has already been introduced with the mechanics of circular motion (see page 66) and is linked to the frequency of rotation by the following formula:

$$\omega = 2\pi f$$

angular velocity       frequency

### EQUATIONS OF UNIFORM ANGULAR ACCELERATION

The definitions of average linear velocity and average linear acceleration can be rearranged to derive the constant acceleration equations (page 11). An equivalent rearrangement derives the equations of constant angular acceleration.

Translational motion		Rotational motion	
Displacement	$s$	Angular displacement	$\theta$
Initial velocity	$u$	Initial angular velocity	$\omega_i$
Final velocity	$v$	Final angular velocity	$\omega_f$
Time taken	$t$	Time taken	$t$
Acceleration	$a$	Angular acceleration	$\alpha$
	[constant]		[constant]
$v = u + at$		$\omega_f = \omega_i + \alpha t$	
$s = ut + \frac{1}{2} at^2$		$\theta = \omega_i t + \frac{1}{2} \alpha t^2$	
$v^2 = u^2 + 2as$		$\omega_f^2 = \omega_i^2 + 2\alpha\theta$	
$s = \frac{(v + u)t}{2}$		$\theta = \frac{(\omega_f + \omega_i)t}{2}$	

Translational motion	Rotational motion
Every particle in the object has the same instantaneous velocity	Every particle in the object moves in a circle around the same axis of rotation
Displacement, $s$ , measured in m	Angular displacement, $\theta$ , measured in radians [rad]
Velocity, $v$ , is the rate of change of displacement measured in $\text{m s}^{-1}$ $v = \frac{ds}{dt}$	Angular velocity, $\omega$ , is the rate of change of angle measured in $\text{rad s}^{-1}$ $\omega = \frac{d\theta}{dt}$
Acceleration, $a$ , is the rate of change of velocity measured in $\text{m s}^{-2}$ $a = \frac{dv}{dt}$	Angular acceleration, $\alpha$ , is the rate of change of angular velocity measured in $\text{rad s}^{-2}$ $\alpha = \frac{d\omega}{dt}$

Comparison of linear and rotational motion

### EXAMPLE: BICYCLE WHEEL

When a bicycle is moving forward at constant velocity  $v$ , the different points on the wheel each have different velocities. The motion of the wheel can be analysed as the addition of the translational and the rotational motion.

#### a) Translational motion

The bicycle is moving forward at velocity  $v$  so the wheel's centre of mass has forward translational motion of velocity  $v$ . All points on the wheel's rim have a translational component forward at velocity  $v$ .

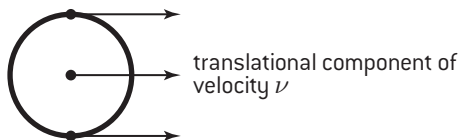

#### b) Rotational motion

The wheel is rotating around the central axis of rotation at a constant angular velocity  $\omega$ . All points on the wheel's rim have a tangential component of velocity  $v (= r\omega)$ .

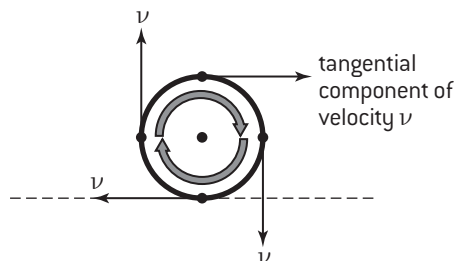

#### c) Combined motion

The motion of the different points on the wheel's rim is the vector addition of the above two components:

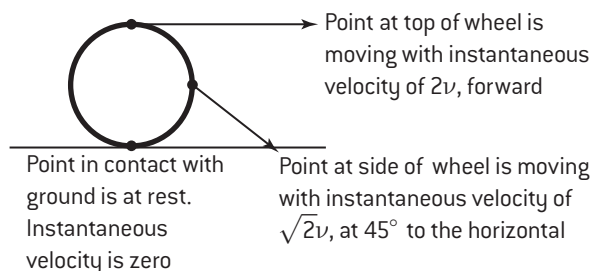

# Translational and rotational relationships

## RELATIONSHIP BETWEEN LINEAR AND ROTATIONAL QUANTITIES

When an object is just rotating about a fixed axis, and there is no additional translational motion of the object, all the individual particles that make up that object have different instantaneous values of linear displacement, linear velocity and linear acceleration. They do, however, all share the same instantaneous values of angular displacement, angular velocity and angular acceleration. The link between these values involves the distance from the axis of rotation to the particle.

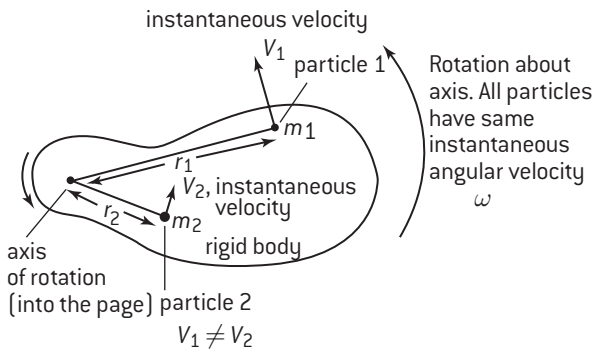

### a) Displacements

Distance travelled on circular path

Angular displacement

$$s = r\theta$$

Distance from axis of rotation to particle

### b) Instantaneous velocities

Linear instantaneous velocity (along the tangent)

Angular velocity

$$v = r\omega$$

Distance from axis of rotation to particle

### c) Accelerations

The total linear acceleration of any particle is made up of two components:

- a) The **centripetal acceleration**,  $a_r$  (towards the axis of rotation – see page 65), also known as the **radial acceleration**.

Tangential velocity

Angular velocity

$$a_r = \frac{v^2}{r} = r\omega^2$$

Centripetal acceleration (along the radius)

Distance from axis of rotation to particle

- b) An additional **tangential acceleration**,  $a_t$ , which results from an angular acceleration taking place. If  $\alpha = 0$ , then  $a_t = 0$ .

Instantaneous acceleration (along the tangent)

Angular acceleration

$$a_t = r\alpha$$

Distance from axis of rotation to particle

The total acceleration of the particle can be found by vector addition of these two components:  $a = r\sqrt{\omega^4 + \alpha^2}$





# Equilibrium examples

## CENTRE OF GRAVITY

The effect of gravity on all the different parts of the object can be treated as a single force acting at the object's **centre of gravity**.

If an object is of uniform shape and density, the centre of gravity will be in the middle of the object. If the object is not uniform, then finding its position is not trivial – it is possible for an object's centre of gravity to be outside the object. Experimentally, if you suspend an object from a point and it is free to move, then the centre of gravity will always end up below the point of suspension.

(a) plank balances if pivot is in middle

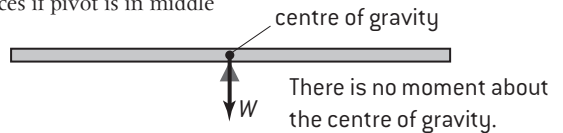

(b) plank rotates clockwise if pivot is to the left

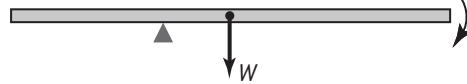

(c) plank rotates anticlockwise if pivot is to the right

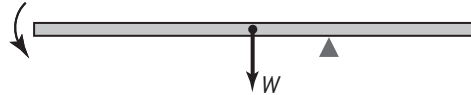

## EXAMPLE 1

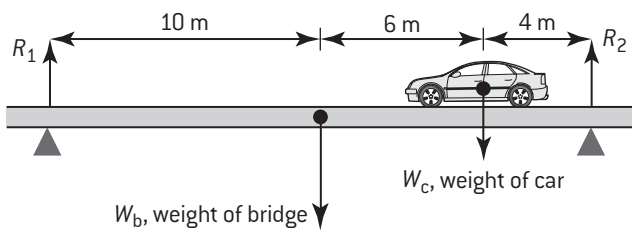

When a car goes across a bridge, the forces (on the bridge) are as shown.

Taking moments about right-hand support:  
clockwise moment = anticlockwise moment

$$(R_1 \times 20 \text{ m}) = (W_b \times 10 \text{ m}) + (W_c \times 4 \text{ m})$$

Taking moments about left-hand support:

$$(R_2 \times 20 \text{ m}) = (W_b \times 10 \text{ m}) + (W_c \times 16 \text{ m})$$

Also, since bridge is not accelerating:

$$R_1 + R_2 = W_b + W_c$$

When solving problems to do with rotational equilibrium remember:

- All forces at an axis have zero moment about that axis.
- You do not have to choose the pivot as the axis about which you calculate torques, but it is often the simplest thing to do (for the reason above).
- You need to remember the sense (clockwise or anticlockwise).
- When solving two-dimensional problems it is sufficient to show that an object is in rotational equilibrium about any ONE axis.
- Newton's laws still apply. Often an object is in rotational AND in translational equilibrium. This can provide a simple way of finding an unknown force.
- The weight of an object can be considered to be concentrated at its centre of gravity.
- If the problem only involves three non-parallel forces, the lines of action of all the forces must meet at a single point in order to be in rotational equilibrium.

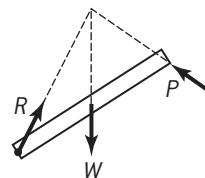

3 forces must meet at a point if in equilibrium

## EXAMPLE 2

A ladder of length 5.0 m leans against a smooth wall (no friction) at an angle of  $30^\circ$  to the vertical.

a) Explain why the ladder can only stay in place if there is friction between the ground and the ladder.

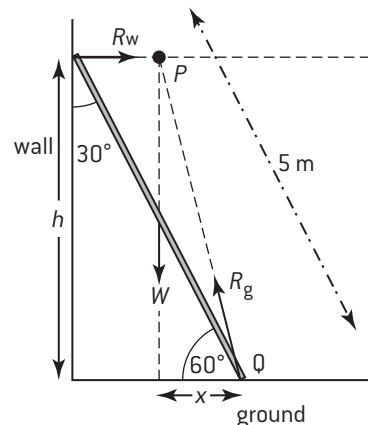

(a) The reaction from the wall,  $R_w$  and the ladder's weight meet at point  $P$ . For equilibrium the force from the ground,  $R_g$  must also pass through this point (for zero torque about  $P$ ).  $\therefore R_g$  is as shown and has a horizontal component (i.e. friction must be acting)

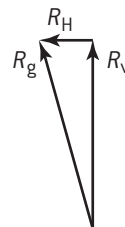

(b) Equilibrium conditions:-

$$\left[ \uparrow \right] \quad W = R_V \quad \text{①}$$

$$\left[ \rightarrow \right] \quad R_H = R_w \quad \text{②}$$

$$\text{moments } R_w h = Wx \quad \text{③}$$

$$F_f \leq \mu_s R$$

$$\therefore R_H \leq \mu_s R_V$$

$$\text{using ① \& ②} \Rightarrow \mu_s \geq \frac{R_w}{W}$$

$$\text{③} \Rightarrow \mu_s \geq \frac{x}{h} = \frac{2.5 \cos 60}{5.0 \sin 60}$$

$$\therefore \mu_s \geq 0.29$$

# Newton's second law – moment of inertia

## NEWTON'S SECOND LAW – DEFINITION OF MOMENT OF INERTIA

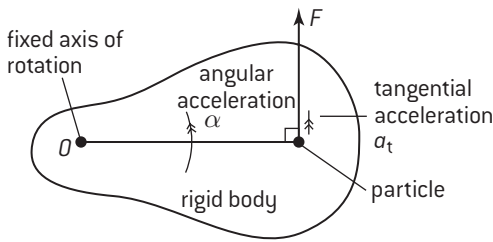

Newton's second law as applied to one particle in a rigid body

Newton's second law applies to every particle that makes up a large object and must also apply if the object is undergoing rotational motion. In the diagram above, the object is made up of lots of small particles each with a mass  $m$ .  $F$  is the *tangential component* of the resultant force that acts on *one particle*. The other component, the radial component, cannot produce angular acceleration so it is not included. For this particle we can apply Newton's second law:

$$F = m a_t = m r \alpha$$

$$\text{so torque } \Gamma = (m r \alpha) r = m r^2 \alpha$$

Similar equations can be created for all the particles that make up the object and summed together:

$$\sum \Gamma = \sum m r^2 \alpha$$

$$\text{or } \sum \Gamma_{\text{ext}} = \alpha \sum m r^2 \quad (1)$$

Note that:

- Newton's third law applies and, when summing up all the torques, the internal torques (which result from the internal forces between particles) must sum to zero. Only the external torques are left.

- Every particle in the object has the same angular acceleration,  $\alpha$ .

The moment of inertia,  $I$ , of an object about a particular axis is defined by the summation below:

$$I = \sum m r^2$$

the distance of the particle from the axis or rotation  
 moment of inertia  
 mass of an individual particle in the object

Note that moment of inertia,  $I$ , is

- A scalar quantity
- Measured in  $\text{kg m}^2$  (not  $\text{kg m}^{-2}$ )
- Dependent on:
  - The mass of the object
  - The way this mass is distributed
  - The axis of rotation being considered.

Using this definition, equation 1 becomes:

resultant external torque in N m      angular acceleration in  $\text{rad s}^{-2}$

$$\Gamma = I \alpha$$

moment of inertia in  $\text{kg m}^2$

This is Newton's second law for rotational motion and can be compared to  $F = ma$

## MOMENTS OF INERTIA FOR DIFFERENT OBJECTS

Equations for moments of inertia in different situations do not need to be memorized.

Object	Axis of rotation	moment of inertia	Object	Axis of rotation	moment of inertia
thin ring (simple wheel) 	through centre, perpendicular to plane	$mr^2$	Sphere 	through centre	$\frac{2}{5} mr^2$
thin ring 	through a diameter	$\frac{1}{2} mr^2$			
disc and cylinder (solid flywheel) 	through centre, perpendicular to plane	$\frac{1}{2} mr^2$	Rectangular lamina 	Through the centre of mass, perpendicular to the plane of the lamina	$m \left( \frac{l^2 + h^2}{12} \right)$
thin rod, length $d$ 	through centre, perpendicular to rod	$\frac{1}{12} md^2$			

### EXAMPLE

A torque of 30 N m acts on a wheel with moment of inertia 600  $\text{kg m}^2$ . The wheel starts off at rest.

a) What angular acceleration is produced?

b) The wheel has a radius of 40 cm. After 1.5 minutes:

i. what is the angular velocity of the wheel?

ii. how fast is a point on the rim moving?

a)  $\Gamma = I \alpha \Rightarrow \alpha = \frac{\Gamma}{I} = \frac{30}{600} = 5.0 \times 10^{-2} \text{ rad s}^{-2}$

b) i.  $\omega = \alpha t = 5.0 \times 10^{-2} \times 90 = 4.5 \text{ rad s}^{-1}$

ii.  $v = r \omega = 0.4 \times 4.5 = 1.8 \text{ m s}^{-1}$

# Rotational dynamics

## ENERGY OF ROTATIONAL MOTION

Energy considerations often provide simple solutions to complicated problems. When a torque acts on an object, work is done. In the absence of any resistive torque, the work done on the object will be stored as rotational kinetic energy.

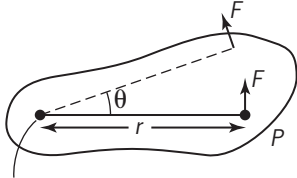

axis of rotation

Calculation of work done by a torque

In the situation above, a force  $F$  is applied and the object rotates. As a result, an angular displacement of  $\theta$  occurs. The work done,  $W$ , is calculated as shown below:

$$W = F \times (\text{distance along arc}) = F \times r\theta = \Gamma\theta$$

$$\text{Using } \Gamma = I\alpha \text{ we know that } W = I\alpha\theta$$

We can apply the constant angular acceleration equation to substitute for  $\alpha\theta$ :

$$\omega_f^2 = \omega_i^2 + 2\alpha\theta$$

$$\therefore W = I \left( \frac{\omega_f^2}{2} - \frac{\omega_i^2}{2} \right) = \frac{1}{2} I\omega_f^2 - \frac{1}{2} I\omega_i^2$$

This means that we have an equation for rotational KE:

$$E_{k_{rot}} = \frac{1}{2} I\omega^2$$

Work done by the torque acting on object = change in rotational KE of object

The total KE is equal to the sum of translational KE and the rotational KE:

$$\text{Total KE} = \text{translational KE} + \text{rotational KE}$$

$$\text{Total KE} = \frac{1}{2} Mv^2 + \frac{1}{2} I\omega^2$$

## ANGULAR MOMENTUM

### For a single particle

The linear momentum,  $p$ , of a particle of mass  $m$  which has a tangential speed  $v$  is  $m v$ .

The angular momentum,  $L$ , is defined as the *moment* of the linear momentum about the axis of rotation

$$\text{Angular momentum, } L = (mv)r = (mr\omega)r = (mr^2)\omega$$

### For a larger object

The angular momentum  $L$  of an object about an axis of rotation is defined as

$$\text{Angular momentum, } L = \sum (mr^2)\omega$$

$$L = I\omega$$

Note that total angular momentum,  $L$ , is:

- a vector (in the same way that a torque is considered to be a vector for calculations)
- measured in  $\text{kg m}^2 \text{ s}^{-1}$  or  $\text{N m s}$
- dependent on all rotations taking place. For example, the total angular momentum of a planet orbiting a star would involve:
  - ◇ the spinning of the planet about an axis through the planet's centre of mass and
  - ◇ the orbital angular momentum about an axis through the star.

## CONSERVATION OF ANGULAR MOMENTUM

In exactly the same way that Newton's laws can be applied to linear motion to derive:

- the concept of the impulse of a force
- the relationship between impulse and change in momentum
- the law of conservation of linear momentum,

then Newton's laws can be applied to angular situations to derive:

- The concept of the **angular impulse**:

Angular impulse is the product of torque and the time for which the torque acts:

$$\text{angular impulse} = \Gamma\Delta t$$

If the torque varies with time then the total angular impulse given to an object can be estimated from the area under the graph showing the variation of torque with time. This is analogous to estimating the total impulse given to an object as a result of a varying force (see page 23).

- The relationship between angular impulse and change in angular momentum:

angular impulse applied to an object = change of angular momentum experienced by the object

- The law of conservation of angular momentum.

The total angular momentum of a system remains constant provided no resultant external torque acts.

Examples:

- a) A skater who is spinning on a vertical axis down their body can reduce their moment of inertia by drawing in their arms. This allows their mass to be redistributed so that the mass of the arms is no longer at a significant distance from the axis of rotation thus reducing  $\sum mr^2$ .

Extended arms mean larger radius and smaller velocity of rotation.

Bringing in her arms decreases her moment of inertia and therefore increases her rotational velocity.

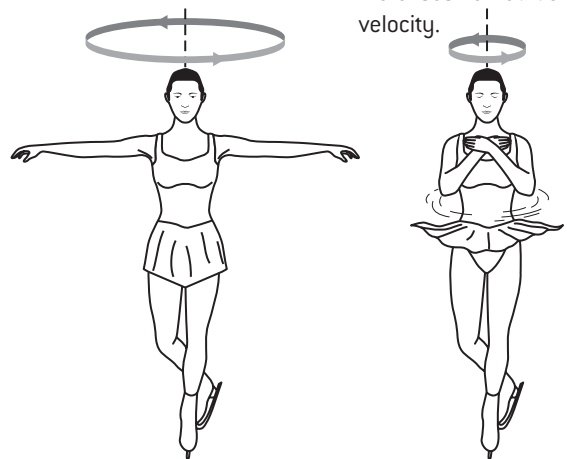

- b) The Earth–Moon system produces tides in the oceans. As a result of the relative movement of water, friction exists between the oceans and Earth. This provides a torque that acts to reduce the Earth's spin on its own axis and thus reduces the Earth's angular momentum. The conservation of angular momentum means that there must be a corresponding increase in the orbital angular momentum of the Earth–Moon system. As a result, the Earth–Moon separation is slowly increasing.

# Solving rotational problems

## SUMMARY COMPARISON OF EQUATIONS OF LINEAR AND ROTATIONAL MOTION

Every equation for linear motion has a corresponding angular equivalent:

	Linear motion	Rotational motion
Physics principles	A resultant external force on a point object causes acceleration. The value of the acceleration is determined by the mass and the resultant force.	A resultant external torque on an extended object causes rotational acceleration. The value of the angular acceleration is determined by the moment of inertia and the resultant torque.
Newton's second law	$F = m a$	$\Gamma = I \alpha$
Work done	$W = F s$	$W = \Gamma \theta$
Kinetic energy	$E_k = \frac{1}{2} m v^2$	$E_{k_{rot}} = \frac{1}{2} I \omega^2$
Power	$P = F v$	$P = \Gamma \omega$
Momentum	$p = m v$	$L = I \omega$
Conservation of momentum	The total linear momentum of a system remains constant provided no resultant external force acts.	The total angular momentum of a system remains constant provided no resultant external torque acts.
Symbols used	Resultant force $F$ Mass $m$ Acceleration $a$ Displacement $s$ Velocity $v$ Linear momentum $p$	Resultant torque $\Gamma$ Moment of inertia $I$ Angular acceleration $\alpha$ Angular displacement $\theta$ Angular velocity $\omega$ Angular momentum $L$

### PROBLEM SOLVING AND GRAPHICAL WORK

When analysing any rotational situation, the simplest approach is to imagine the equivalent linear situation and use the appropriate equivalent relationships.

- a) Graph of angular displacement vs time

This graph is equivalent to a graph of linear displacement vs time. In the linear situation, the area under the graph does not represent any useful quantity and the gradient of the line at any instant is equal to the instantaneous velocity (see page 10). **Thus the gradient of an angular displacement vs time graph gives the instantaneous angular velocity.**

- b) Graph of angular velocity vs time

This graph is equivalent to a graph of linear velocity vs time. In the linear situation, the area under the graph represents the distance gone and the gradient of the line at any instant is equal to the instantaneous acceleration (see page 10). **Thus the area under an angular velocity vs time graph gives the total angular displacement and the gradient of an angular velocity vs time graph gives the instantaneous angular acceleration.**

- c) Graph of torque vs time

This graph is equivalent to a graph of force vs time. In the linear situation, the area under the graph represents the total impulse given to the object which is equal to the change of momentum of the object (see page 23). **Thus the area under the torque vs time graph represents the total angular impulse given to the object which is equal to the change of angular momentum.**

### EXAMPLE

A solid cylinder, initially at rest, rolls down a 2.0 m long slope of angle  $30^\circ$  as shown in the diagram below:

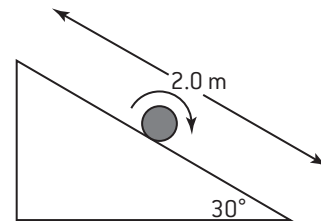

The mass of the cylinder is  $m$  and the radius of the cylinder is  $R$ . Calculate the velocity of the cylinder at the bottom of the slope.

Answer:

Vertical height fallen by cylinder =  $2.0 \sin 30 = 1.0$  m

$$PE \text{ lost} = mgh$$

$$KE \text{ gained} = \frac{1}{2} mv^2 + \frac{1}{2} I\omega^2$$

$$\text{but } I = \frac{1}{2} mR^2 \quad (\text{cylinder}) \text{ see page 156}$$

$$\text{and } \omega = \frac{v}{R}$$

$$\begin{aligned} \Rightarrow KE \text{ gained} &= \frac{1}{2} mv^2 + \frac{1}{2} \frac{mR^2}{2} \cdot \frac{v^2}{R^2} \\ &= \frac{1}{2} mv^2 + \frac{1}{4} mv^2 \\ &= \frac{3}{4} mv^2 \end{aligned}$$

Conservation of energy

$$\Rightarrow mgh = \frac{3}{4} mv^2$$

$$\therefore v = \sqrt{\frac{4gh}{3}}$$

$$= \sqrt{\frac{4 \times 9.8 \times 1.0}{3}}$$

$$= 3.61 \text{ m s}^{-1}$$



# Thermodynamic systems and concepts

## DEFINITIONS

Historically, the study of the behaviour of ideal gases led to some very fundamental concepts that are applicable to many other situations. These laws, otherwise known as the laws of **thermodynamics**, provide the modern physicist with a set of very powerful intellectual tools.

The terms used need to be explained.

**Thermodynamic system** Most of the time when studying the behaviour of an ideal gas in particular situations, we focus on the macroscopic behaviour of the gas as a whole. In terms of work and energy, the gas can gain or lose thermal energy and it can do work or work can be done on it. In this context, the gas can be seen as a **thermodynamic system**.

**The surroundings** If we are focusing our study on the behaviour of an ideal gas, then everything else can be called its **surroundings**. For example the expansion of a gas means that work is done by the gas on the surroundings (see below).

**Heat  $Q$**  In this context heat refers to the transfer of a quantity of thermal energy between the system and its surroundings. This transfer must be as a result of a temperature difference.

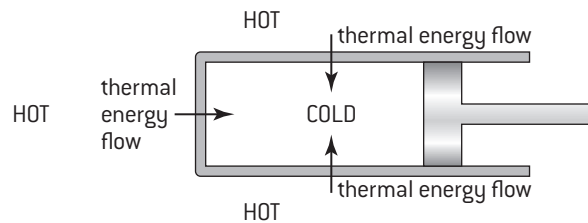

**Work  $W$**  In this context, work refers to the macroscopic transfer of energy. For example

1. work done = force  $\times$  distance

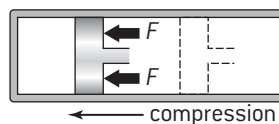

When a gas is compressed, work is done on the gas

When a gas is compressed, the surroundings do work on it. When a gas expands it does work on the surroundings.

2. work done = potential difference  $\times$  current  $\times$  time

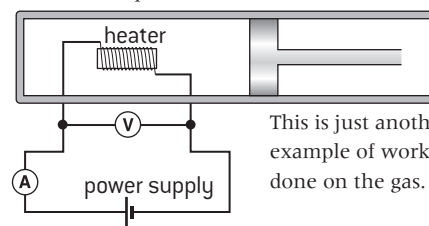

This is just another example of work being done on the gas.

**Internal energy  $U$  ( $\Delta U = \text{change in internal energy}$ )** The internal energy can be thought of as the energy held within a system. It is the sum of the PE due to the intermolecular forces and the kinetic energy due to the random motion of the molecules. See page 26.

This is different to the total energy of the system, which would also include the overall motion of the system and any PE due to external forces.

In thermodynamics, it is the changes in internal energy that are being considered. If the internal energy of a gas is increased, then its temperature must increase. A change of phase (e.g. liquid  $\rightarrow$  gas) also involves a change of internal energy.

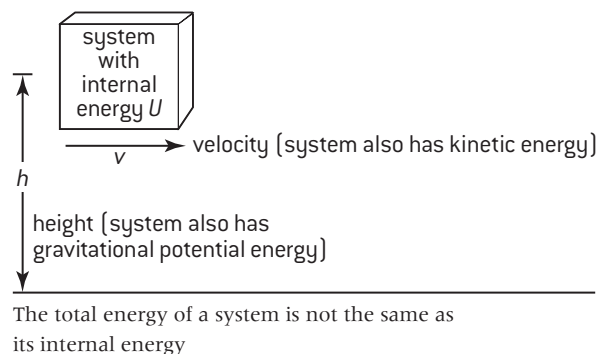

**Internal energy of an ideal monatomic gas** The internal energy of an ideal gas depends only on temperature. When the temperature of an ideal gas changes from  $T$  to  $(T + \Delta T)$  its internal energy changes from  $U$  to  $(U + \Delta U)$ . The same  $\Delta U$  always produces the same  $\Delta T$ . Since the temperature is related to the average kinetic energy per molecule (see page 30),  $\overline{E_k} = \frac{3}{2} k_B T = \frac{3}{2} \frac{R}{N_A} T$ , the internal energy  $U$ , is the sum of the total random kinetic energies of the molecules:

$$U = nN_A \overline{E_k} = \frac{3}{2} nRT \quad [n = \text{number of moles; } N_A = \text{Avogadro's constant}]$$

# Work done by an ideal gas

## WORK DONE DURING EXPANSION AT CONSTANT PRESSURE

Whenever a gas expands, it is doing work on its surroundings. If the pressure of the gas is changing all the time, then calculating the amount of work done is complex. This is because we cannot assume a constant force in the equation of work done (work done = force  $\times$  distance). If the pressure changes then the force must also change. If the pressure is constant then the force is constant and we can calculate the work done.

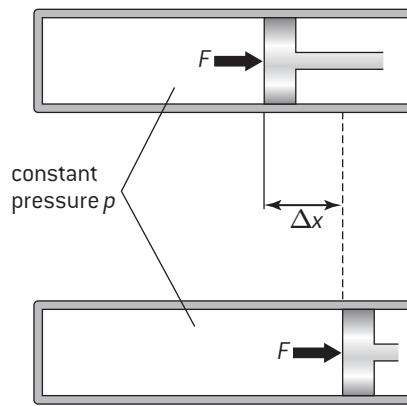

Work done  $W = \text{force} \times \text{distance}$   
 $= F\Delta x$

Since pressure =  $\frac{\text{force}}{\text{area}}$

$F = pA$

therefore

$W = pA\Delta x$

but  $A\Delta x = \Delta V$

so work done =  $p\Delta V$

So if a gas increases its volume ( $\Delta V$  is positive) then the gas does work ( $W$  is positive)

## pV DIAGRAMS AND WORK DONE

It is often useful to represent the changes that happen to a gas during a thermodynamic process on a  $pV$  diagram. An important reason for choosing to do this is that the area under the graph represents the work done. The reasons for this are shown below.

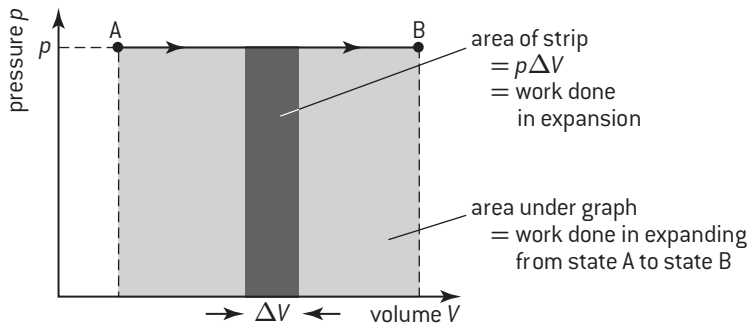

This turns out to be generally true for any thermodynamic process.

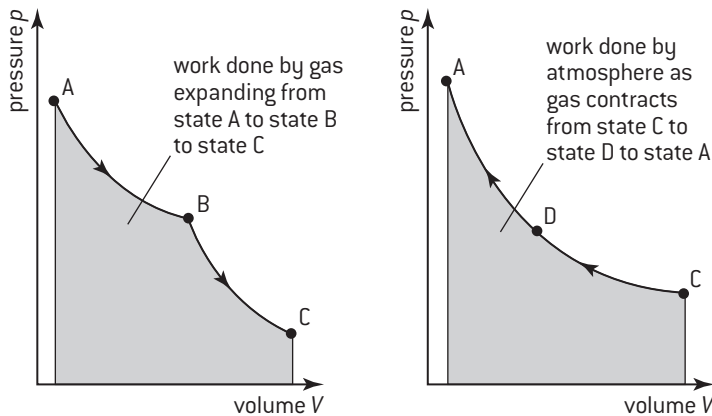

# The first law of thermodynamics

## FIRST LAW OF THERMODYNAMICS

There are three fundamental laws of thermodynamics. The first law is simply a statement of the principle of energy conservation as applied to the system. If an amount of thermal energy  $Q$  is given to a system, then one of two things must happen (or a combination of both). The system can increase its internal energy  $\Delta U$  or it can do work  $W$ .

As energy is conserved

$$Q = \Delta U + W$$

It is important to remember what the signs of these symbols mean. They are all taken from the system's 'point of view'.

$Q$  If this is **positive**, then thermal energy is going into the system.  
If it is **negative**, then thermal energy is going out of the system.

$\Delta U$  If this is **positive**, then the internal energy of the system is **increasing**. (The temperature of the gas is increasing.)  
If it is **negative**, the internal energy of the system is **decreasing**. (The temperature of the gas is decreasing.)

$W$  If this is **positive**, then the **system is doing work** on the surroundings. (The gas is expanding.)  
If it is **negative**, the **surroundings are doing work** on the system. (The gas is contracting.)

## IDEAL GAS PROCESSES

A gas can undergo any number of different types of change or process. Four important processes are considered below. In each case the changes can be represented on a pressure–volume diagram and the first law of thermodynamics must apply. To be precise, these diagrams represent a type of process called a reversible process.

### 1. Isochoric

(isovolumetric)

In an isochoric process, also called an isovolumetric process, the gas has a constant volume. The diagram below shows an **isochoric decrease** in pressure.

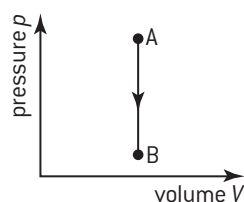

Isochoric (volumetric) change

$$V = \text{constant, or} \\ \frac{p}{T} = \text{constant}$$

$Q$  negative

$\Delta U$  negative ( $T \downarrow$ )

$W$  zero

### 2. Isobaric

In an isobaric process the gas has a constant pressure. The diagram below shows an **isobaric expansion**.

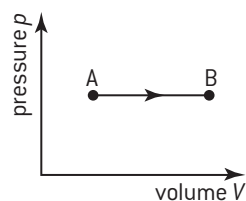

Isobaric change

$$p = \text{constant, or} \\ \frac{V}{T} = \text{constant}$$

$Q$  positive

$\Delta U$  positive ( $T \uparrow$ )

$W$  positive

### 3. Isothermal

In an isothermal process the gas has a constant temperature. The diagram below shows an **isothermal expansion**.

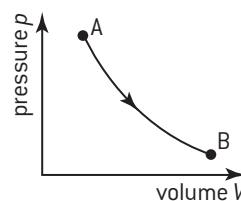

Isothermal change

$$T = \text{constant, or} \\ pV = \text{constant}$$

$Q$  positive

$\Delta U$  zero

$W$  positive

### 4. Adiabatic

In an adiabatic process there is no thermal energy transfer between the gas and the surroundings. This means that if the gas does work it must result in a decrease in internal energy. A rapid compression or expansion is approximately adiabatic. This is because done quickly there is not sufficient time for thermal energy to be exchanged with the surroundings. The diagram below shows an **adiabatic expansion**.

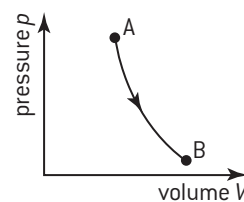

Adiabatic change

$Q$  zero

$\Delta U$  negative ( $T \downarrow$ )

$W$  positive

For a monatomic gas, the equation for an adiabatic process is

$$pV^{\frac{5}{3}} = \text{constant}$$

## EXAMPLE

A monatomic gas doubles its volume as a result of an adiabatic expansion. What is the change in pressure?

$$p_1 V_1^{\frac{5}{3}} = p_2 V_2^{\frac{5}{3}} \\ \frac{p_2}{p_1} = \left( \frac{V_1}{V_2} \right)^{\frac{5}{3}} \\ = 0.5^{\frac{5}{3}} \\ = 0.31$$

$\therefore$  final pressure = 31% of initial pressure

# Second law of thermodynamics and entropy

## SECOND LAW OF THERMODYNAMICS

Historically the **second law of thermodynamics** has been stated in many different ways. All of these versions can be shown to be equivalent to one another.

In principle there is nothing to stop the complete conversion of thermal energy into useful work. In practice, a gas can not continue to expand forever – the apparatus sets a physical limit. Thus **the continuous conversion of thermal energy into work requires a cyclical process – a heat engine.**

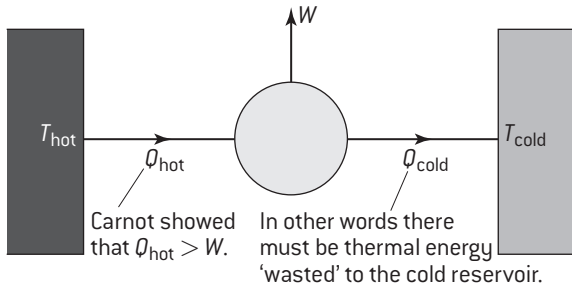

This realization leads to possibly the simplest formulation of the second law of thermodynamics (the **Kelvin-Planck** formulation).

**No heat engine, operating in a cycle, can take in heat from its surroundings and totally convert it into work.**

Other possible formulations include the following:

**No heat pump can transfer thermal energy from a low-temperature reservoir to a high-temperature reservoir without work being done on it** (Clausius).

**Heat flows from hot objects to cold objects.**

The concept of **entropy** leads to one final version of the second law.

**The entropy of the Universe can never decrease.**

## EXAMPLES

The first and second laws of thermodynamics both must apply to all situations. Local decreases of entropy are possible so long as elsewhere there is a corresponding increase.

1. A refrigerator is an example of a heat pump.

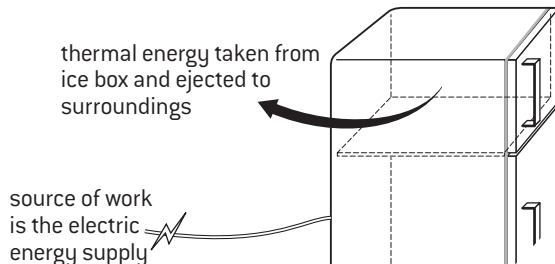

A refrigerator

2. It should be possible to design a theoretical system for propelling a boat based around a heat engine. The atmosphere could be used as the hot reservoir and cold water from the sea could be used as the cold reservoir. The movement of the boat through the water would be the work done. This is possible BUT it cannot continue to work for ever. The sea would be warmed and the atmosphere would be cooled and eventually there would be no temperature difference.

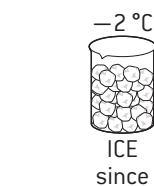

entropy decrease of ice formation < entropy increase of surroundings

increasing temperature of surroundings →



entropy decrease of ice formation = entropy increase of surroundings



entropy decrease of ice formation > entropy increase of surroundings

## ENTROPY AND ENERGY DEGRADATION

Entropy is a property that expresses the disorder in the system.

The details are not important but the entropy  $S$  of a system is linked to the number of possible arrangements  $W$  of the system.  $[S = k_B \ln(W)]$

Because molecules are in random motion, one would expect roughly equal numbers of gas molecules in each side of a container.

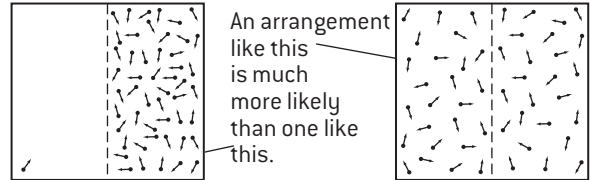

The number of ways of arranging the molecules to get the set-up on the right is greater than the number of ways of arranging the molecules to get the set-up on the left. This means that the entropy of the system on the right is greater than the entropy of the system on the left.

In any random process the amount of disorder will tend to increase. In other words, the total entropy will always increase. The entropy change  $\Delta S$  is linked to the thermal energy change  $\Delta Q$  and the temperature  $T$ .  $(\Delta S = \frac{\Delta Q}{T})$

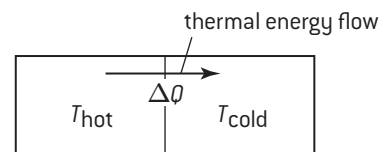

$$\text{decrease of entropy} = \frac{\Delta Q}{T_{\text{hot}}} \quad \text{increase of entropy} = \frac{\Delta Q}{T_{\text{cold}}}$$

When thermal energy flows from a hot object to a colder object, overall the total entropy has increased.

In many situations the idea of energy **degradation** is a useful concept. The more energy is shared out, the more degraded it becomes – it is harder to put it to use. For example, the internal energy that is 'locked' up in oil can be released when the oil is burned. In the end, all the energy released will be in the form of thermal energy – shared among many molecules. It is not feasible to get it back.

3. Water freezes at  $0^\circ\text{C}$  because this is the temperature at which the entropy increase of the surroundings (when receiving the latent heat) equals the entropy decrease of the water molecules becoming more ordered. It would not freeze at a higher temperature because this would mean that the overall entropy of the system would decrease.



# Heat engines and heat pumps

## HEAT ENGINES

A central concept in the study of thermodynamics is the **heat engine**. A heat engine is any device that uses a source of thermal energy in order to do work. It converts heat into work. The internal combustion engine in a car and the turbines that are used to generate electrical energy in a power station are both examples of heat engines. A block diagram representing a generalized heat engine is shown below.

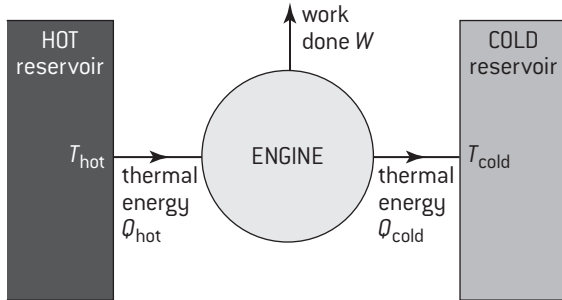

Heat engine

In this context, the word **reservoir** is used to imply a constant temperature source (or sink) of thermal energy. Thermal energy can be taken from the hot reservoir without causing the temperature of the hot reservoir to change. Similarly thermal energy can be given to the cold reservoir without increasing its temperature.

An ideal gas can be used as a heat engine. The  $pV$  diagram right represents a simple example. The four-stage cycle returns the gas to its starting conditions, but the gas has done work. The area enclosed by the cycle represents the amount of work done.

In order to do this, some thermal energy must have been taken from a hot reservoir (during the isovolumetric increase in pressure and the isobaric expansion). A different amount of thermal energy must have been ejected to a cold reservoir (during the isovolumetric decrease in pressure and the isobaric compression).

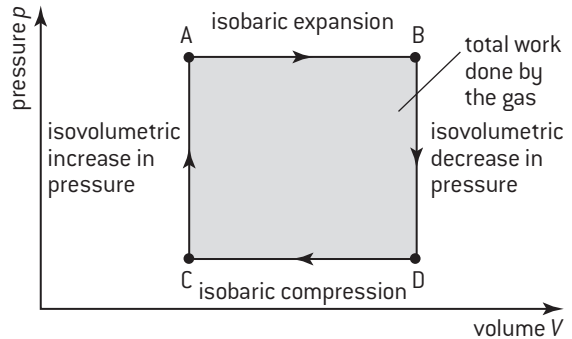

The thermal efficiency of a heat engine is defined as

$$\eta = \frac{\text{work done}}{\text{(thermal energy taken from hot reservoir)}}$$

This is equivalent to

$$\eta = \frac{\text{rate of doing work}}{\text{(thermal power taken from hot reservoir)}}$$

$$\eta = \frac{\text{useful work done}}{\text{energy input}}$$

The cycle of changes that results in a heat engine with the maximum possible efficiency is called the **Carnot cycle**.

## HEAT PUMPS

A **heat pump** is a heat engine being run in reverse. A heat pump causes thermal energy to be moved from a cold reservoir to a hot reservoir. In order for this to be achieved, mechanical work must be done.

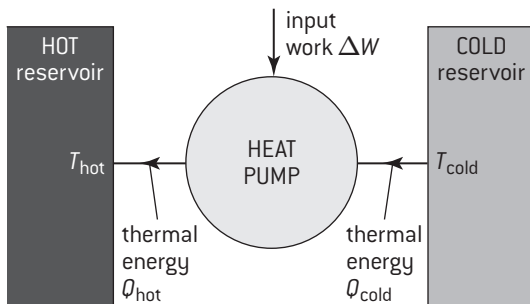

Heat pump

Once again an ideal gas can be used as a heat pump. The thermodynamic processes can be exactly the same ones as were used in the heat engine, but the processes are all opposite. This time an anticlockwise circuit will represent the cycle of processes.

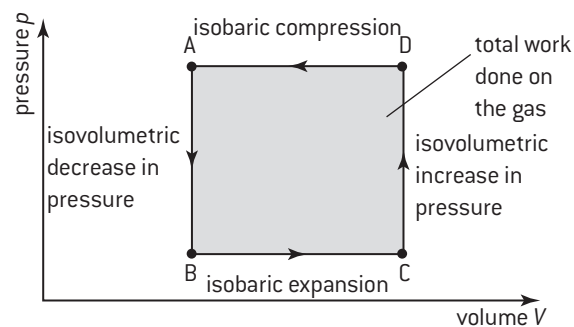

## CARNOT CYCLES AND CARNOT THEOREM

The Carnot cycle represents the cycle of processes for a theoretical heat engine with the maximum possible efficiency. Such an idealized engine is called a **Carnot engine**.

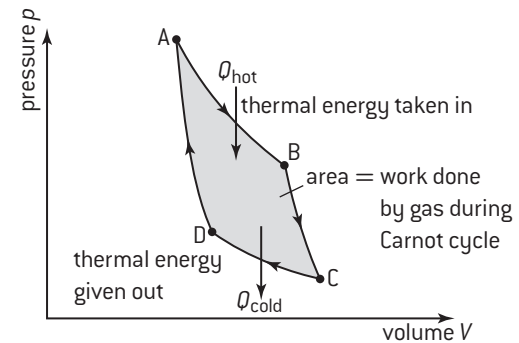

Carnot cycle

It consists of an ideal gas undergoing the following processes.

- Isothermal expansion (A → B)
- Adiabatic expansion (B → C)
- Isothermal compression (C → D)
- Adiabatic compression (D → A)

The temperatures of the hot and cold reservoirs fix the maximum possible efficiency that can be achieved.

The efficiency of a Carnot engine can be shown to be

$$\eta_{\text{Carnot}} = 1 - \frac{T_{\text{cold}}}{T_{\text{hot}}} \quad (\text{where } T \text{ is in kelvin})$$

An engine operates at 300 °C and ejects heat to the surroundings at 20 °C. The maximum possible theoretical efficiency is

$$\eta_{\text{Carnot}} = 1 - \frac{293}{573} = 0.49 = 49\%$$

# HL Fluids at rest

## DEFINITIONS OF DENSITY AND PRESSURE

The symbol representing density is the Greek letter rho,  $\rho$ . The average density of a substance is defined by the following equation:

$$\rho = \frac{m}{V}$$

average density
mass
volume

- Density is a scalar quantity.
- The SI units of density are  $\text{kg m}^{-3}$ .
- Densities can also be quoted in  $\text{g cm}^{-3}$  (see conversion factor below)
- The density of water is  $1 \text{ g cm}^{-3} = 1,000 \text{ kg m}^{-3}$

Pressure at any point in a fluid (a gas or a liquid) is defined in terms of the force,  $\Delta F$ , that acts normally (at  $90^\circ$ ) to a small area,  $\Delta A$ , that contains the point.

$$p = \frac{\Delta F}{\Delta A}$$

pressure
normal force
area

- Pressure is a scalar quantity – the force has a direction but the pressure does not. Pressure acts equally in all directions.
- The SI unit of pressure is  $\text{N m}^{-2}$  or pascals (Pa).  $1 \text{ Pa} = 1 \text{ N m}^{-2}$
- Atmospheric pressure  $\approx 10^5 \text{ Pa}$
- Absolute pressure is the actual pressure at a point in a fluid. Pressure gauges often record the **difference** between absolute pressure and atmospheric pressure. Thus if a difference pressure gauge gives a reading of  $2 \times 10^5 \text{ Pa}$  for a gas, the absolute pressure of the gas is  $3 \times 10^5 \text{ Pa}$ .

## VARIATION OF FLUID PRESSURE

The pressure in a fluid increases with depth. If two points are separated by a vertical distance,  $d$ , in a fluid of constant density,  $\rho_f$ , then the pressure difference,  $\Delta p$ , between these two points is:

$$\Delta p = \rho_f g d$$

density of fluid
gravitational field strength
depth

The total pressure at a given depth in a liquid is the addition of the pressure acting at the surface (atmospheric pressure) and the additional pressure due to the depth:

$$P = P_0 + \rho_f g d$$

Atmospheric pressure
density of fluid
depth
Total pressure
gravitational field strength

Note that:

- Pressure can be expressed in terms of the equivalent depth (or head) in a known liquid. Atmospheric pressure is approximately the same as exerted by a 760 mm high column of mercury (Hg) or a 10 m column of water.
- As pressure is dependent on depth, the pressures at two points that are at the same horizontal level in the same liquid must be the same provided they are connected by that liquid and the liquid is static.

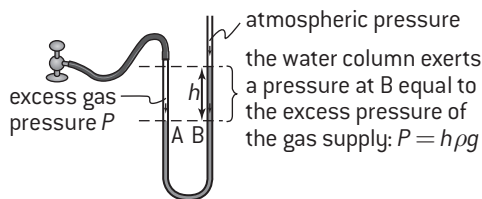

- The pressure is independent of the cross-sectional area – this means that liquids will always find their own level.

## HYDROSTATIC EQUILIBRIUM

A fluid is in **hydrostatic equilibrium** when it is at rest. This happens when all the forces on a given volume of fluid are balanced. Typically external forces (e.g. gravity) are balanced by a pressure gradient across the volume of fluid (pressure increases with depth – see above).

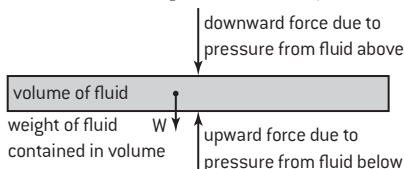

## BUOYANCY AND ARCHIMEDES' PRINCIPLE

Archimedes' principle states that when a body is immersed in a fluid, it experiences a buoyancy upthrust equal in magnitude to the weight of the fluid displaced.  $B = \rho_f V_f g$

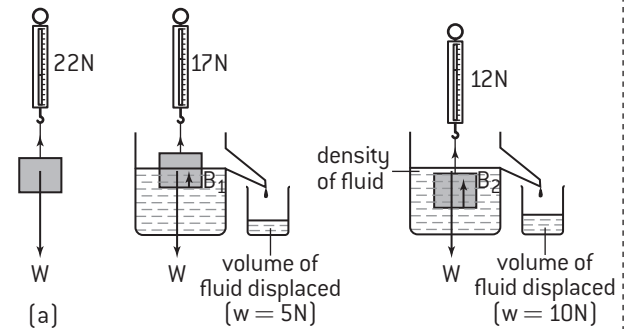

A consequence of this principle is that a floating object displaces its own weight of fluid.

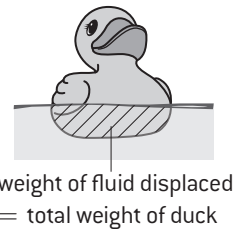

## PASCAL'S PRINCIPLE

Pascal's principle states that the pressure applied to an enclosed liquid is transmitted to every part of the liquid, whatever the shape it takes. This principle is central to the design of many **hydraulic** systems and is different to how solids respond to forces.

When a solid object (e.g. an incompressible stick) is pushed at one end and its other end is held in place, then the same force will be exerted on the restraining object.

Incompressible solids transmit forces whereas incompressible liquids transmit pressures.

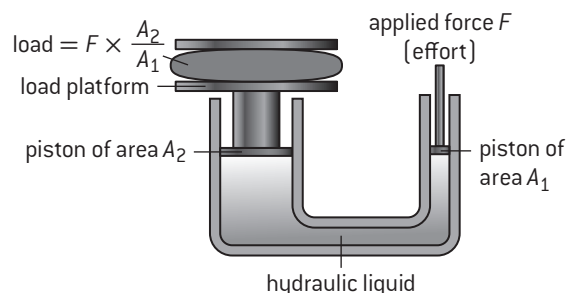

# HL Fluids in motion – Bernoulli effect

## THE IDEAL FLUID

In most real situations, fluid flow is extremely complicated. The following properties define an ideal fluid that can be used to create a simple model. This simple model can be later refined to be more realistic.

An ideal fluid:

- Is **incompressible** – thus its density will be constant.

- Is **non-viscous** – as a result of fluid flow, no energy gets converted into thermal energy. See page 167 for the definition of the viscosity of a real fluid.
- Involves a **steady flow** (as opposed to a **turbulent**, or chaotic, flow) of fluid. Under these conditions the flow is laminar (see box below). See page 167 for an analysis of turbulent flow.
- Does **not have angular momentum** – it does not rotate.

## LAMINAR FLOW, STREAMLINES AND THE CONTINUITY EQUATION

When the flow of a liquid is steady or **laminar**, different parts of the fluid can have different instantaneous velocities. The flow is said to be laminar if every particle that passes through a given point has the same velocity whenever the observation is made. The opposite of **laminar flow**, turbulent flow, takes place when the particles that pass through a given point have a wide variation of velocities depending on the instant when the observation is made (see page 167).

A **streamline** is the path taken by a particle in the fluid and laminar flow means that all particles that pass through a given point in the fluid must follow the same streamline. The direction of the tangent to a streamline gives the direction of the instantaneous velocity that the particles of the fluid have at that point. No fluid ever crosses a streamline. Thus a collection of streamlines can together define a **tube of flow**. This is tubular region of fluid where fluid only enters and leaves the tube through its ends and never through its sides.

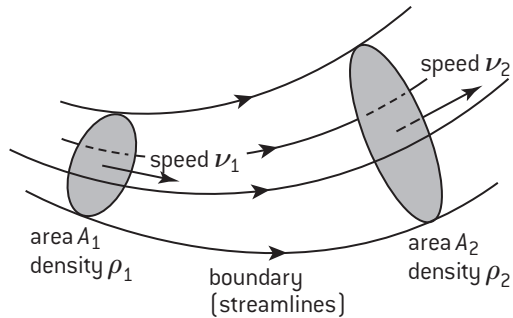

In a time  $\Delta t$ , the mass,  $m_1$ , entering the cross-section  $A_1$  is

$$m_1 = \rho_1 A_1 v_1 \Delta t$$

Similarly the mass,  $m_2$ , leaving the cross-section  $A_2$  is

$$m_2 = \rho_2 A_2 v_2 \Delta t$$

Conservation of mass applies to this tube of flow, so

$$\rho_1 A_1 v_1 = \rho_2 A_2 v_2$$

This is an ideal fluid and thus incompressible meaning  $\rho_1 = \rho_2$ , so

$$A_1 v_1 = A_2 v_2 \text{ or } Av = \text{constant}$$

This is the **continuity equation**.

## THE BERNOULLI EFFECT

When a fluid flows into a narrow section of a pipe:

- The fluid must end up moving at a higher speed (continuity equation).
- This means the fluid must have been accelerated forwards.

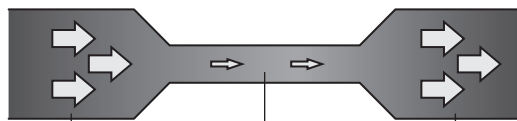

higher pressure  
lower speed

lower pressure  
higher speed

higher pressure  
lower speed

- This means there must be a pressure difference forwards with a lower pressure in the narrow section and a higher pressure in the wider section.

Thus an increase in fluid speed must be associated with a decrease in fluid pressure. This is the Bernoulli effect – the greater the speed, the lower the pressure and vice versa.

## THE BERNOULLI EQUATION

The Bernoulli equation results from a consideration of the work done and the conservation of energy when an ideal fluid changes:

- its speed (as a result of a change in cross-sectional area)
- its vertical height as a result of work done by the fluid pressure.

The equation identifies a quantity that is always constant along any given streamline:

$$\frac{1}{2} \rho v^2 + \rho g z + p = \text{constant}$$

density of fluid    speed of fluid particles    vertical height  
fluid pressure  
density of fluid    gravitational field strength

Note that:

- The first term ( $\frac{1}{2} \rho v^2$ ), can be thought of as the dynamic pressure.
- The last two terms ( $\rho g z + p$ ), can be thought of as the static pressure.
- Each term in the equation has several possible units:  $\text{N m}^{-2}$ , Pa,  $\text{J m}^{-3}$ .
- The last of the above units leads to a new interpretation for the Bernoulli equation:

$$\begin{array}{ccccccc} \text{KE} & & \text{gravitational PE} & & & & \\ \text{per unit} & + & \text{per unit} & + & \text{pressure} & = & \text{constant} \\ \text{volume} & & \text{volume} & & & & \end{array}$$

# HL Bernoulli – examples

## APPLICATIONS OF THE BERNOULLI EQUATION

a) Flow out of a container

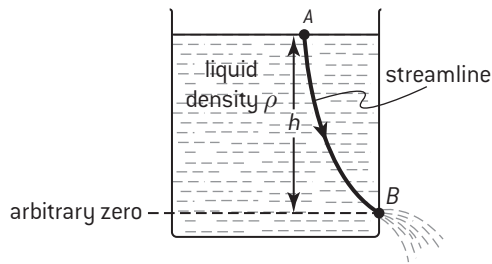

To calculate the speed of fluid flowing out of a container, we can apply Bernoulli's equation to the streamline shown above.

At A,  $p =$  atmospheric and  $v =$  zero

At B,  $p =$  atmospheric and  $v = ?$

$$\frac{1}{2}\rho v^2 + \rho g z + p = \text{constant}$$

$$\therefore 0 + h\rho g + p = \frac{1}{2}\rho v^2 + 0 + p$$

$$v = \sqrt{2gh}$$

b) Venturi tubes

A Venturi meter allows the rate of flow of a fluid to be calculated from a measurement of pressure difference between two different cross-sectional areas of a pipe.

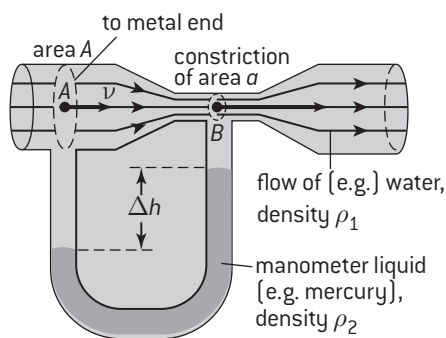

- The pressure difference between A and B can be calculated by taking readings of  $\Delta h$  and  $\rho_2$  from the attached manometer:

$$P_A - P_B = \Delta h \rho_2 g$$

- This value and measurements of A, a and  $\rho_1$  allows the fluid speed at A to be calculated by using Bernoulli's equation and the equation of continuity

$$v = \frac{2\Delta h \rho_2 g}{\rho_1 \left( \frac{A}{a} \right)^2 - 1}$$

- The rate of flow of fluid through the pipe is equal to  $A \times v$

c) Fragrance spray

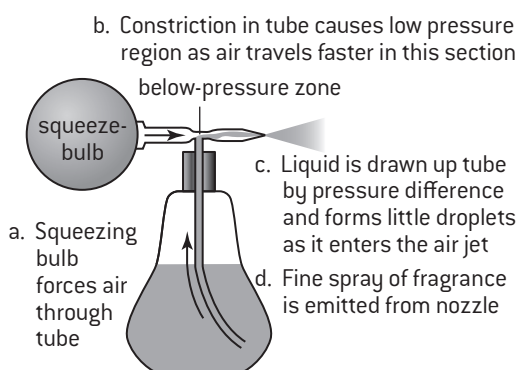

d) Pitot tube to determine the speed of a plane

A pitot tube is attached facing forward on a plane. It has two separate tubes:

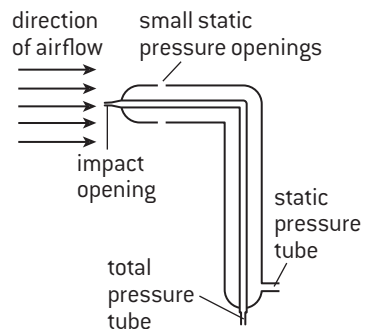

- The front hole (impact opening) is placed in the airstream and measures the total pressure (sometimes called the stagnation pressure),  $P_T$ .
- The side hole(s) measures the static pressure,  $P_s$ .
- The difference between  $P_T$  and  $P_s$  is the dynamic pressure. The Bernoulli equation can be used to calculate airspeed:

$$P_T - P_s = \frac{1}{2}\rho v^2$$

$$v = \sqrt{\frac{2(P_T - P_s)}{\rho}}$$

e) Aerofoil (aka airfoil)

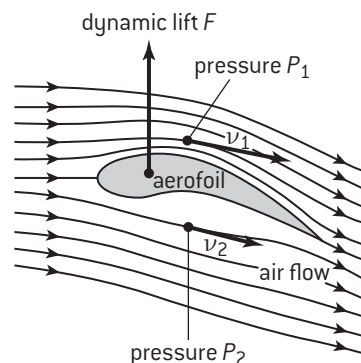

Note that:

- Streamlines closer together above the aerofoil imply a decrease in cross-sectional area of equivalent tubes of flow above the aerofoil.
- Decrease in cross-sectional area of tube of flow implies increased velocity of flow above the aerofoil (equation of continuity).  $v_1 > v_2$
- Since  $v_1 > v_2$ ,  $P_1 < P_2$
- Bernoulli equation can be used to calculate the pressure difference (height difference not relevant) which can support the weight of the aeroplane.
- When angle of attack is too great, the flow over the upper surface can become turbulent. This reduces the pressure difference and leads to the plane '**stalling**'.



# HL Viscosity

## DEFINITION OF VISCOSITY

An ideal fluid does not resist the relative motion between different layers of fluid. As a result there is no conversion of work into thermal energy during laminar flow and no external forces are needed to maintain a steady rate of flow. Ideal fluids are non-viscous whereas real fluids are viscous. In a viscous fluid, a steady external force is needed to maintain a steady rate of flow (no acceleration). Viscosity is an internal friction between different layers of a fluid which are moving with different velocities.

The definition of the viscosity of a fluid,  $\eta$ , (Greek letter Nu) is in terms of two new quantities, the **tangential stress**,  $\tau$ , and the **velocity gradient**,  $\frac{\Delta v}{\Delta y}$  (see RH side).

The coefficient of viscosity  $\eta$  is defined as:

$$\eta = \frac{\text{tangential stress}}{\text{velocity gradient}} = \frac{F/A}{\Delta v/\Delta y}$$

- The units of  $\eta$  are  $\text{N s m}^{-2}$  or  $\text{kg m}^{-1} \text{s}^{-1}$  or  $\text{Pa s}$
- Typical values at room temperature:
  - ◊ Water:  $1.0 \times 10^{-3} \text{ Pa s}$
  - ◊ Thick syrup:  $1.0 \times 10^2 \text{ Pa s}$
- Viscosity is very sensitive to changes of temperature.

For a class of fluid, called **Newtonian fluids**, experimental measurements show that tangential stress is proportional to velocity gradient (e.g. many pure liquids). For these fluids the coefficient of viscosity is constant provided external conditions remain constant.

## A) Tangential stress

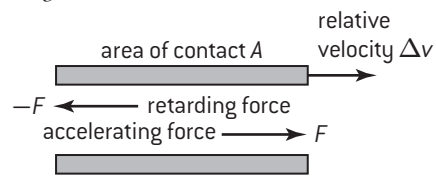

The tangential stress is defined as:

$$\tau = \frac{F}{A}$$

- Units of tangential stress are  $\text{N m}^{-2}$  or  $\text{Pa}$

## B) Velocity gradient

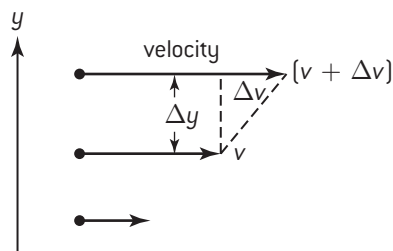

The velocity gradient is defined as:

$$\text{velocity gradient} = \frac{\Delta v}{\Delta y}$$

- Units of velocity gradient are  $\text{s}^{-1}$

## STOKES' LAW

Stokes' law predicts the viscous drag force  $F_D$  that acts on a perfect sphere when it moves through a fluid:

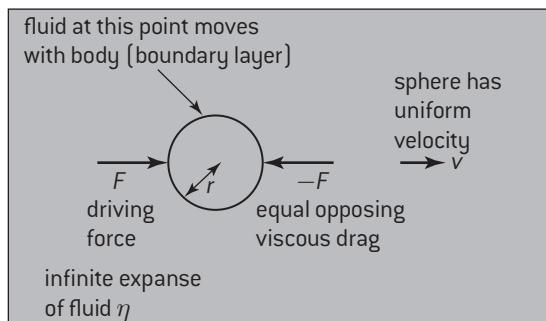

Drag force acting on sphere in  $\text{N}$       viscosity of fluid in  $\text{Pa s}$

$$F_D = 6\pi\eta r v$$

radius of sphere in  $\text{m}$       velocity of sphere in  $\text{m s}^{-1}$

Note Stokes' law assumes that:

- The speed of the sphere is small so that:
  - ◊ the flow of fluid past the sphere is streamlined
  - ◊ there is no slipping between the fluid and the sphere

- The fluid is infinite in volume. Real spheres falling through columns of fluid can be affected by the proximity of the walls of the container.
- The size of the particles of the fluid is very much smaller than the size of the sphere.

The forces on a sphere falling through a fluid at terminal velocity are as shown below:

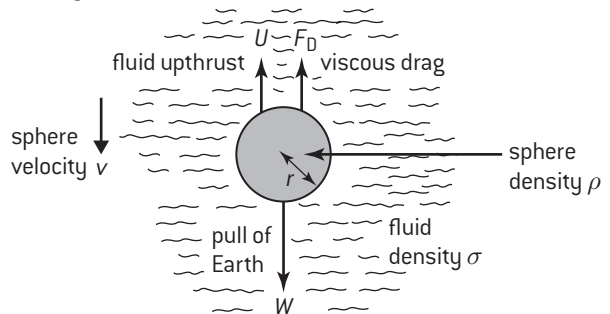

At terminal velocity  $v_t$ ,

$$W = U + F_D$$

$$F_D = U - W$$

$$6\pi\eta r v_t = \frac{4}{3}\pi r^3(\rho - \sigma)g$$

$$\therefore v_t = \frac{2r^2(\rho - \sigma)g}{9\eta}$$

## TURBULENT FLOW – THE REYNOLDS NUMBER

Streamline flow only occurs at low fluid flow rates. At high flow rates the flow becomes turbulent:



It is extremely difficult to predict the exact conditions when fluid flow becomes turbulent. When considering fluid flow down a pipe, a useful number to consider is the Reynolds number,  $R$ , which is defined as:

$$\text{Reynolds number } R = \frac{\text{speed of bulk flow } v \times \text{radius of pipe } r \times \text{density of fluid } \rho}{\text{viscosity of fluid } \eta}$$

Note that:

- The Reynolds number does not have any units – it is just a ratio.
- Experimentally, fluid flow is often laminar when  $R < 1000$  and turbulent when  $R > 2000$  but precise predictions are difficult.

# HL Forced oscillations and resonance (1)

## DAMPING

**Damping** involves a frictional force that is always in the opposite direction to the direction of motion of an oscillating particle. As the particle oscillates, it does work against this resistive (or dissipative) force and so the particle loses energy. As the total energy of the particle is proportional to the (amplitude)<sup>2</sup> of the SHM, the amplitude decreases exponentially with time.

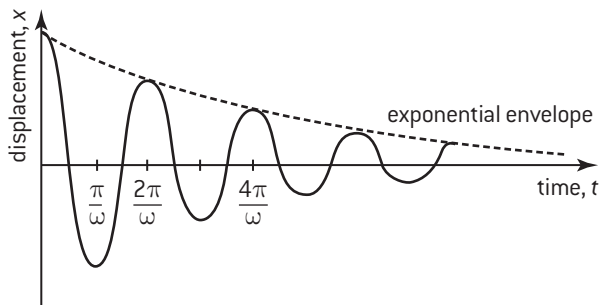

The above example shows the effect of **light damping** (the system is said to be **underdamped**) where the resistive force is small so a small fraction of the total energy is removed each cycle. The time period of the oscillations is not affected and the oscillations continue for a significant number of cycles. The time taken for the oscillations to 'die out' can be long.

**Heavy damping or overdamping** involves large resistive forces (e.g. the SHM taking place in a viscous liquid) and can completely prevent the oscillations from taking place. The time taken for the particle to return to zero displacement can again be long.

Critical damping involves an intermediate value for resistive force such that the time taken for the particle to return to zero displacement is a minimum. Effectively there is no 'overshoot'. Examples of critically damped systems include electric meters with moving pointers and door closing mechanisms.

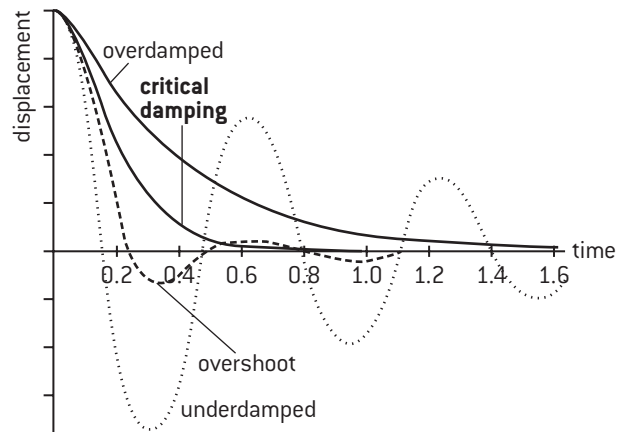

## NATURAL FREQUENCY AND RESONANCE

If a system is temporarily displaced from its equilibrium position, the system will oscillate as a result. This oscillation will be at the **natural frequency of vibration** of the system. For example, if you tap the rim of a wine glass with a knife, it will oscillate and you can hear a note for a short while. Complex systems tend to have many possible modes of vibration each with its own natural frequency.

It is also possible to force a system to oscillate at any frequency that we choose by subjecting it to a changing force that varies with the chosen frequency. This periodic driving force must be provided from outside the system. When this **driving frequency** is first applied, a combination of natural and forced oscillations take place which produces complex **transient** oscillations. Once the amplitude of the transient oscillations 'die down', a steady condition is achieved in which:

- The system oscillates at the driving frequency.
- The amplitude of the forced oscillations is fixed. Each cycle energy is dissipated as a result of damping and the driving force does work on the system. The overall result is that the energy of the system remains constant.

- The amplitude of the forced oscillations depends on:
  - ◊ the comparative values of the natural frequency and the driving frequency
  - ◊ the amount of damping present in the system.

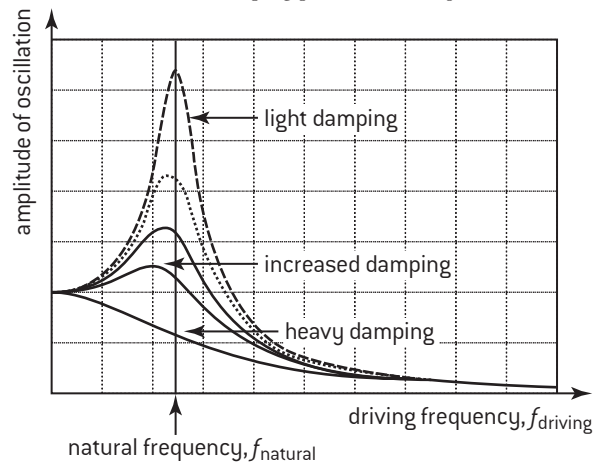

**Resonance** occurs when a system is subject to an oscillating force at exactly the same frequency as the natural frequency of oscillation of the system.

## Q FACTOR AND DAMPING

The degree of damping is measured by a quantity called the quality factor or Q factor. It is a ratio (no units) and the definition is:

$$Q = 2\pi \frac{\text{energy stored}}{\text{energy lost per cycle}}$$

Since the energy stored is proportional to the square of amplitude of the oscillation, measurements of decreasing amplitude with time can be used to calculate the Q factor. The Q factor is approximately equal to the number of oscillations that are completed before damping stops the oscillation.

Typical orders of magnitude for different Q-factors:

Car suspension:	1
Simple pendulum:	10 <sup>3</sup>
Guitar string:	10 <sup>3</sup>
Excited atom:	10 <sup>7</sup>

When a system is in resonance and its amplitude is constant, the energy provided by the driving frequency during one cycle is all used to overcome the resistive forces that cause damping. In this situation, the Q factor can be calculated as:

$$Q = 2\pi \times \text{resonant frequency} \times \frac{\text{energy stored}}{\text{power loss}}$$

# HL Resonance (2)

## PHASE OF FORCED OSCILLATIONS

After transient oscillations have died down, the frequency of the forced oscillations equals the driving frequency. The phase relationship between these two oscillations is complex and depends on how close the driven system is to resonance:

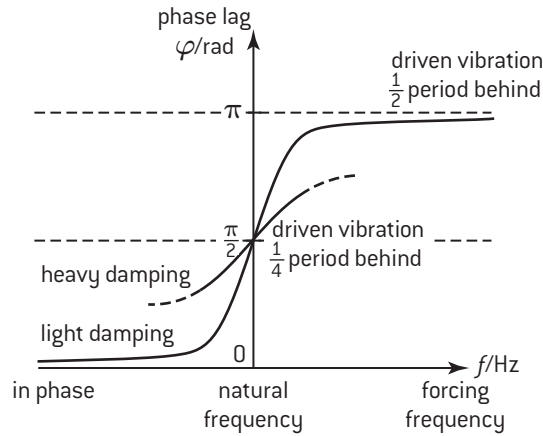

## EXAMPLES OF RESONANCE

	Comment
Vibrations in machinery	When in operation, the moving parts of machinery provide regular driving forces on the other sections of the machinery. If the driving frequency is equal to the natural frequency, the amplitude of a particular vibration may get dangerously high. e.g. at a particular engine speed a truck's rear view mirror can be seen to vibrate.
Quartz oscillators	A quartz crystal feels a force if placed in an electric field. When the field is removed, the crystal will oscillate. Appropriate electronics are added to generate an oscillating voltage from the mechanical movements of the crystal and this is used to drive the crystal at its own natural frequency. These devices provide accurate clocks for microprocessor systems.
Microwave generator	Microwave ovens produce electromagnetic waves at a known frequency. The changing electric field is a driving force that causes all charges to oscillate. The driving frequency of the microwaves provides energy, which means that water molecules in particular are provided with kinetic energy – i.e. the temperature is increased.
Radio receivers	Electrical circuits can be designed (using capacitors, resistors and inductors) that have their own natural frequency of electrical oscillations. The free charges (electrons) in an aerial will feel a driving force as a result of the frequency of the radio waves that it receives. Adjusting the components of the connected circuit allows its natural frequency to be adjusted to equal the driving frequency provided by a particular radio station. When the driving frequency equals the circuit's natural frequency, the electrical oscillations will increase in amplitude and the chosen radio station's signal will dominate the other stations.
Musical instruments	Many musical instruments produce their sounds by arranging for a column of air or a string to be driven at its natural frequency which causes the amplitude of the oscillations to increase.
Greenhouse effect	The natural frequency of oscillation of the molecules of greenhouse gases is in the infra-red region. Radiation emitted from the Earth can be readily absorbed by the greenhouse gases in the atmosphere. See page 92 for more details.

# IB Questions – option B – engineering physics

1. A sphere of mass  $m$  and radius  $r$  rolls, without slipping, from rest down an inclined plane. When it reaches the base of the plane, it has fallen a vertical distance  $h$ . Show that the speed of the sphere,  $v$ , when it arrives at the base of the incline is given by:

$$v = \sqrt{\frac{10gh}{7}} \quad [4]$$

2. A flywheel of moment of inertia  $0.75 \text{ kg m}^2$  is accelerated uniformly from rest to an angular speed of  $8.2 \text{ rad s}^{-1}$  in  $6.5 \text{ s}$ .
- Calculate the resultant torque acting on the flywheel during this time. [2]
  - Calculate the rotational kinetic energy of the flywheel when it rotates at  $8.2 \text{ rad s}^{-1}$  [2]
  - The radius of the flywheel is  $15 \text{ cm}$ . A breaking force applied on the circumference and brings it to rest from an angular speed of  $8.2 \text{ rad s}^{-1}$  in exactly 2 revolutions. Calculate the value of the breaking force. [2]
3. A fixed mass of a gas undergoes various changes of temperature, pressure and volume such that it is taken round the  $p$ - $V$  cycle shown in the diagram below.

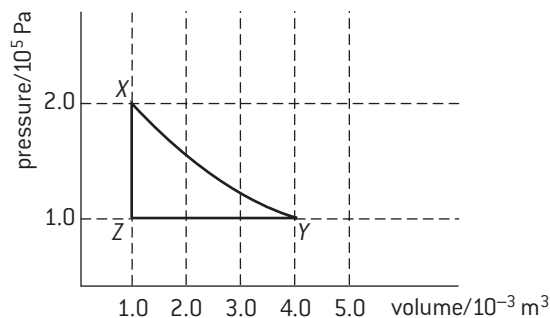

The following sequence of processes takes place during the cycle.

$X \rightarrow Y$  the gas expands at constant temperature and the gas absorbs energy from a reservoir and does  $450 \text{ J}$  of work.

$Y \rightarrow Z$  the gas is compressed and  $800 \text{ J}$  of thermal energy is transferred from the gas to a reservoir.

$Z \rightarrow X$  the gas returns to its initial stage by absorbing energy from a reservoir.

- Is there a change in internal energy of the gas during the processes  $X \rightarrow Y$ ? Explain. [2]
- Is the energy absorbed by the gas during the process  $X \rightarrow Y$  less than, equal to or more than  $450 \text{ J}$ ? Explain. [2]
- Use the graph to determine the work done on the gas during the process  $Y \rightarrow Z$ . [3]
- What is the change in internal energy of the gas during the process  $Y \rightarrow Z$ ? [2]
- How much thermal energy is absorbed by the gas during the process  $Z \rightarrow X$ ? Explain your answer. [2]
- What quantity is represented by the area enclosed by the graph? Estimate its value. [2]
- The overall efficiency of a heat engine is defined as

$$\text{Efficiency} = \frac{\text{net work done by the gas during a cycle}}{\text{total energy absorbed during a cycle}}$$

If this  $p$ - $V$  cycle represents the cycle for a particular heat engine determine the efficiency of the heat engine. [2]

4. In a **diesel** engine, air is initially at a pressure of  $1 \times 10^5 \text{ Pa}$  and a temperature of  $27^\circ \text{C}$ . The air undergoes the cycle of changes listed below. At the end of the cycle, the air is back at its starting conditions.

- An **adiabatic compression** to  $1/20$ th of its original volume.
  - A brief **isobaric expansion** to  $1/10$ th of its original volume.
  - An **adiabatic expansion** back to its original volume.
  - A cooling down at constant volume.
- Sketch, with labels, the cycle of changes that the gas undergoes. Accurate values are not required. [3]
  - If the pressure after the **adiabatic compression** has risen to  $6.6 \times 10^6 \text{ Pa}$ , calculate the temperature of the gas. [2]
  - In which of the four processes:
    - is work done **on** the gas? [1]
    - is work done **by** the gas? [1]
    - does ignition of the air-fuel mixture take place? [1]
  - Explain how the 2nd law of thermodynamics applies to this cycle of changes. [2]



- With the aid of diagrams, explain
  - What is meant by laminar flow
  - The Bernoulli effect
  - Pascal's principle
  - An ideal fluid [8]
- Oil, of viscosity  $0.35 \text{ Pa s}$  and density  $0.95 \text{ g cm}^{-3}$ , flows through a pipe of radius  $20 \text{ cm}$  at a velocity of  $2.2 \text{ m s}^{-1}$ . Deduce whether the flow is laminar or turbulent. [4]
- A pendulum clock maintains a constant amplitude by means of an electric power supply. The following information is available for the pendulum:

Maximum kinetic energy:  $5 \times 10^{-2} \text{ J}$

Frequency of oscillation:  $2 \text{ Hz}$

Q factor:  $30$

Calculate:

- The driving frequency of the power supply [3]
- The power needed to drive the clock. [3]